

**HIGH QUARITY LOW COST DEW POINT
HYGROMETER**

SMART DEW POINT HYGROMETER



Features

- Accuracy $\pm 0.3^{\circ}\text{C dp}$
- Dew or Ice Auto detector
- Measurement range $- 20 \sim + 60^{\circ}\text{C dp}$
- Units(dp,RH%,T $^{\circ}\text{C}$) can be changes by user
- Two alarm outputs
- Auto-cleaning

Applications

- Heating furnace
- Clean Rooms
- Engine tests
- To prevent Condensation
- For labo
- As a calibration standard

Introduction

SMART DEW is multipurpose high performance optical dew point hygrometer with automatic frost detection. Hygrometers which work on classical principle of chilled mirror suffer a potential measurement error of up to 8 percent of measured value if condensate present on the mirror surface is super-cooled water rather than ice. The error can be several times larger than the manufacture's claimed measurement accuracy for this type of instrument. For this reason some manufacturers build-in microscope in to instruments so that confirmation of the presence of ice may be made by human eye before a reading is considered reliable, or use complex electronic predictor systems which are very costly.

The SMART DEW hygrometer, is a breakthrough in chilled-mirror hygrometer technology. The instrument uses SMART-ICE, a simple low-cost and reliable optical detection system which tells if ice or super-cooled water is present on mirror surface. If super-cooled water, the measured reading is automatically corrected. The user is assured of an accurate reading in all conditions without microscope confirmation. This unique feature means that SMART DEW hygrometers may be confidently used in continuous applications without manual supervision.

Detail

Errors with chilled mirror hygrometers occur because, particularly when moisture in clean gases is measured, ice does not immediately form on mirror surface below freezing temperature of 0°C. Condensate may continue to be present in form of super-cooled water to temperatures even as low as -40°C. Error may be in region of 2,5degrees Celcius or more.

In very expensive instruments electronic predictor compensation systems attempt to overcome the problem or a pre-cooling cycle is performed in order to force the formation of ice.

About ice detection

The SMART DEW solves the problem by shining collimated light on mirror surface at a ten degree angle of incidence. Two detectors are employed to receive reflected light. Detector A measures decrease of reflected light which occurs when water forms. Detector B measures light reflected from ice

crystals once ice has formed. Outputs from the two detectors are fed to a micro-computer which adjusts measured reading according to whether ice or water is on mirror surface. This simple and effective technology means that users can be assured of measured result. In case of competitor products this kind of assurance is available only in much more expensive instruments.

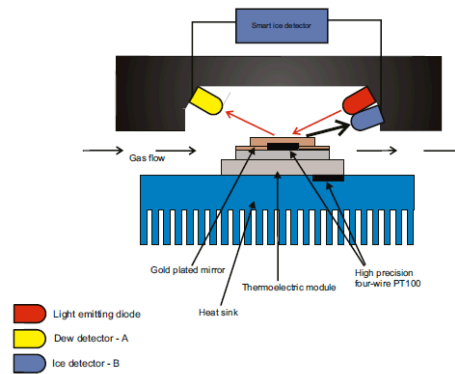

Front description

SMART DEW panel contains two LED displays, first one of them is bigger, and the second one is smaller. At the bigger display are displayed humidity. At the smaller one are displayed ambient temperature.

Base version of SMART DEW, without ambient temperature sensor, measures only absolute humidity, so only dew point temperature and g/m³ could be displayed. Smaller display is turned off.

Displayed units are highlighted under display window. Units could be changes by user.

States of ararms(relays outputs) are showed by highlight indicators AL1,AL2.

At SMART DEW panel are also four buttons:

- Enter key- uses to enter to the main menu, choose next level of menu or confirm changes value.
- Esc key- uses to back at higher level of menu or cancel changes value.
- Up/Down key- uses to increment/decrement changing value. The speed of increment/decrement depends of holding time button.

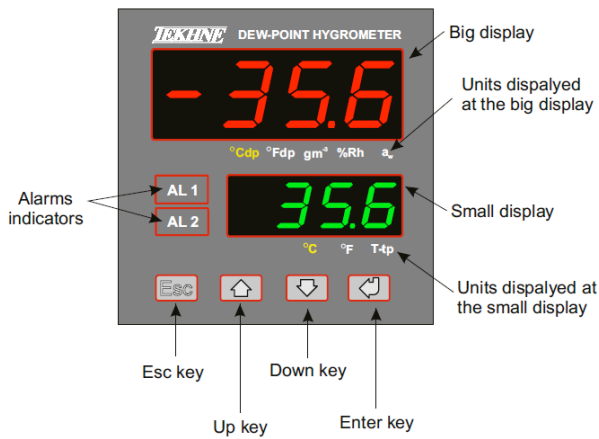

Main menu

SMART DEW works in three modes: normalmode, menu mode and cleaning mirror mode. In normal mode, current values of measurements are displayed and transmitted by analogue outputs. In menu mode meter is still taking the measurements, but didn't shows the results. In cleaning mirror mode displays and outputs are frozen at the last results.

To enter to main menu press and hold Enter button until "SET" will be displayed at the big display. In menu mode, big display shows higher level (function) of menu. In this mode small display shows lower level (function) of menu or editing value.

Rear view and terminals

SMART DEW is equipped in six screw compact terminals blocks. Each terminal is different, so, there is no possibility of mistake.

- Dew point sensor terminals to connect optional temperature sensor.
 - PT100 sensor terminals to connect optional temperature sensor.
 - Power terminals to connect power supply.
 - It is necessary to power SMART DEW by grounded power cord.**
 - Analog outputs terminals to connect external process monitor or system controller.
 - Alarms outputs terminals to connect external alarm indicator or other executive unit.
- This outputs could be set as simple ON/OFF controller.
- Serial port terminals to connect SMART DEW to the computer. SMART DEW cooperate with software application.

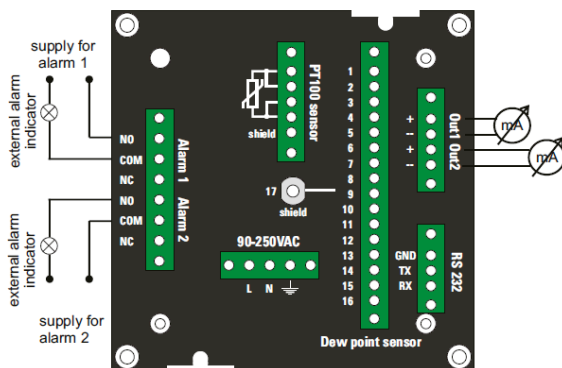

- Dew point sensor terminal:
- | | |
|--------------|----------------------------|
| 1- yellow | 9- navy blue |
| 2- purple | 10- red |
| 3- green | 11- brown/yellow |
| 4- grey | 12- brown/green |
| 5- pink/grey | 13- brown |
| 6- black | 14- white |
| 7- red/grey | 15- white/green |
| 8- pink | 16- white/yellow |
| | 17- shield of sensor cable |

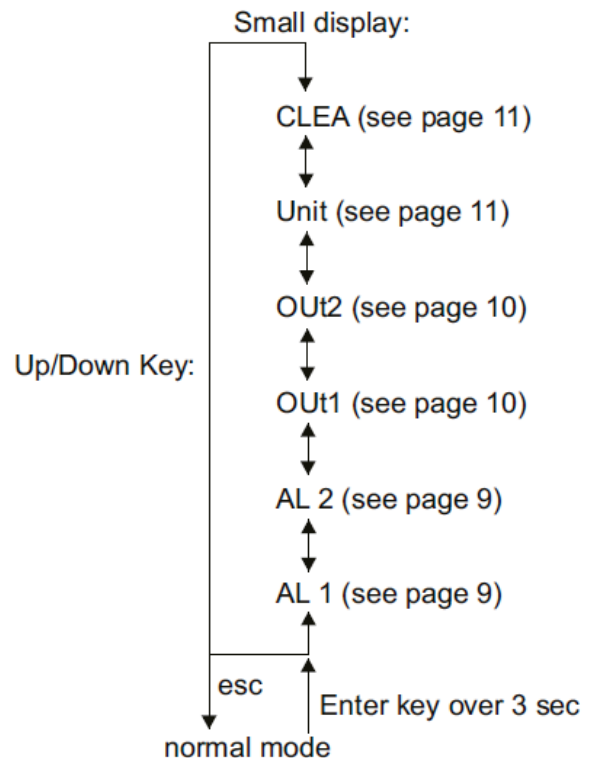

Press Enter button to go to selected function:

- AL1-settings of alarm1
- AL2-settings of alarm2
- OUT1-settings of analog output1
- OUT2-settings of analog output2
- Unit-changing displayed units
- CLEA-changing mirror cleaning interval

or ESC button to back to normal mode.

About alarms

SMART DEW is equipped in two independent alarm's outputs. Each alarm could be working in six modes. In active state alarm's relay is set and panel indicator is turn on. Alarm 1 is related with value displayed at big display, alarm 2 is related with value displayed at small display.

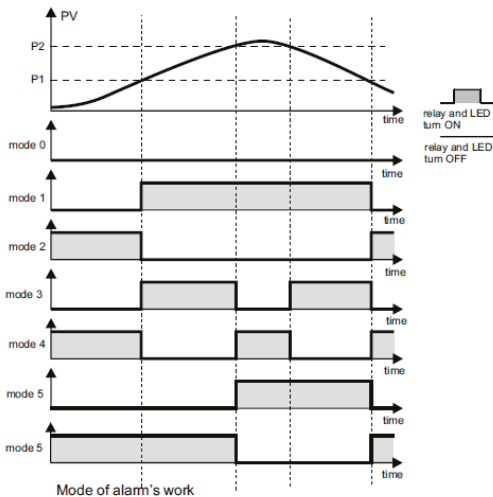

- Mode 0 - alarm is turned off
- Mode 1 - top alarm
- Mode 2 - bottom alarm
- Mode 3 - inside alarm
- Mode 4 - outside alarm
- Mode 5 - simple ON/OFF controller with hysteresis for cooling.
- Mode 6 - simple ON/OFF controller with hysteresis for heating.

Caution!!

For correct work, value P1 should be set below then P2 ($P1 < P2$)

Alarm settings

Each alarm, (relay output) has three parameters: mode, down threshold and up threshold. That values are setting in submenu AL 1 and AL 2. For access main menu press and hold enter button over 3 seconds, "SET" will be displayed at big display. Then choose AL 1 or AL 2 at small display by clicking Up and Down key. To confirm your choice press Enter. Now, it is possible to change settings. Range of changes (min and max) is limited in dependence of current unit for each alarm.

choosing value to edit

editing value

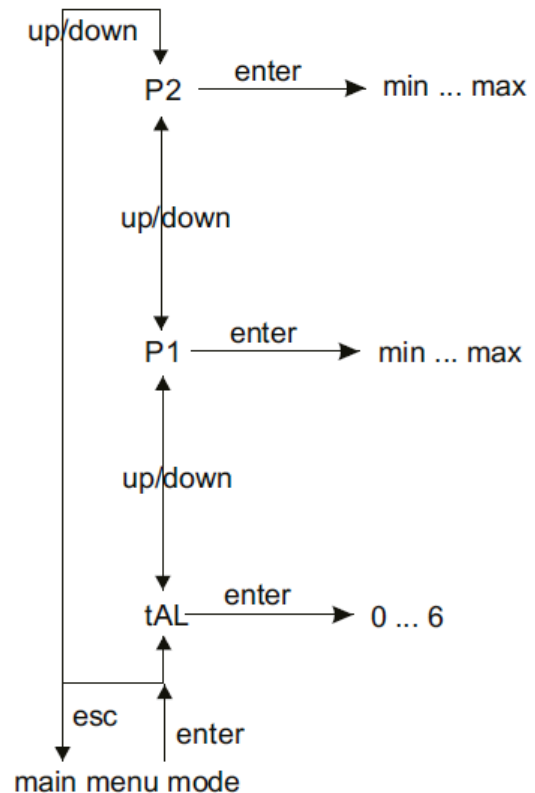

After update value, press:

-enter button to apply and store changes

-esc button to cancel changes

and back to upper level of menu.

Set points (P1, P2) are valid for any unit which is chosen.

Analogue outputs

SMART DEW is equipped in two independent analogue current outputs. Each output could be 0-20mA or 4-20mA. Output 1 is related with value displayed at the big display, output 2 is related with value displayed at the small display. Soon, it will be completely independent parameters.

Each output, has three parameters: mode (0-20mA or 4-20mA), down threshold and up threshold. That values are settings in submenu OU1 and OU2. For access main menu press and hold enter button over 3 seconds, "SET" will be displayed at big display. Then choose OU1 or OU2 at small display by clicking Up and Down key. To confirm your choice press Enter. Submenu OU1 and OU2 (displayed at the big display) allows the setting and ranging of the analog outputs. The maximum and minimum value of output (Hi and Lo) is limited in dependence of current unit for each output separately.

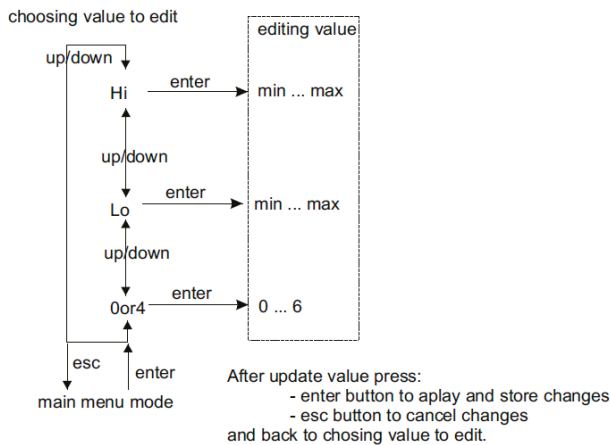

Caution!!

For correct work, value P1 should be set below then P2(P1<P2)

Units

SMART DEW can display process variables: absolute humidity (dewpoint in , dewpoint in F, g/m³), relative humidity(%Rh,aw), ambient temperature in °F, ambient temperature in F, temperature difference.

To change any of the values, go to Unit submenu (Press and hold enter button over 3 seconds, “SET” will be displayed at big display. Then choose Unit at the small display by clicking Up and Down key. To confirm your choice press Enter, “Unit” will be displayed at the big display). Now, Up button changes units for big display, alarm 1, and analogue output 1 (°Cdp, °Fdp, gm-3, %Rh or aw), and Down button changes units for small display, alarm 2, and output 2 (°C, °F or T-dp)

Cleaning the mirror

SMART DEW is cleaning the mirror by programmed time cycle (interval time). Process of cleaning starts by capturing the data (during cleaning time a constant value is displayed and transmitted) and cooling the mirror well below the dew point such that a thick dew or frost layer forms on the mirror. Then the mirror is rapidly heated to 70°C for one minute. During the heating a significant amount of souble and some non-souble contamination id flash evaporated. After that,

SMART DEW is returned to normal measure mode.

To change interval time value, go to “CLEA” submenu (Press and hold Enter button over 3 second, “SET” will be displayed at big display. Then choose “CLEA” at the small display by clicking Up or Down key. To confirm your choose press Enter). “CLEA” will be displayed at the big display, and at the small one will be displayed that interval time. To change it, press Up or Down button, to incress or decrease value expressed in hours. Setting zero turned off cleaning proceses.

Special features Offset

Offset is setting in case of solid difference between real humidity and measured humidity.

This parameter can compensates static methodological error of mesured.

To change value of offset, go to “SPEC” submenu (Press and hold Enter button over 3 seconds, “SET” will be displayed at big display. Then choose “SPEC” at the small display by clicking Up or Down key. To confirm your choose press Enter). “SPEC” will be displayed at the big display. Choose “OFFS” at the small display and press Enter key. Set wanted offset (range from -10.0 to 10.0) value displaying at the small display by using Up/Down keys. To confirm press Enter. Press twice Esc key to come back to normal mode.

Special features Mean filter

SMART DEW is equipped with mean filter which length of time constant can be modify by user. Default length is 256. This value is compromise between stable results and response time of humidity changing. If displayed value is unstable or fluctuate, the length to time constant of mean filter should be increased. If dispalyed value is stable user could decrease the length of time constant of mean filter to makes response time shorter.

To change length of time constant of mean filter, go to “SPEC” submenu (Press and hold Enter button over 3 seconds, “SET” will be displayed at big display. Then choose “SPEC” at the small display by clicking Up or Down key. To confirm your choose press Enter). “SPEC” will be displayed at the big display. Choose “Fltr” at the small

display
end press Enter key. Set wanted length of time
constant of mean filter (range from 1 to 512) value,
which is displaying at the small display by using
Up/Down keys. To confirm press Enter. Press twice
Esc key to come back to normal mode.

Software

Attached software doesn't need installation. User
must copy file cmh10.exe to the local hard disc
drive
only. Application was made to work at
Windows platform..

Application communicates with SMART DEW
hygrometer using serial interface. Important when
USB converter is using: USB converters creates a
virtual COM port on the computer. Be sure that
number of this port is not higher than 8. If it is higher
than 8, change the number in virtual port settings.

Application characteristics:

- in one time displaying non-relative and relative
humidity.
- displaying gas ambient temperature.
- humidity and temperature presented at the chart.
- measuring data are saved on the hard disc drive.
- saved data can be easily loaded later and presented
at the chart.
- saved data can be also easily readed by popular
programs (like Excel)

Sheet "Hygrometer"

This sheet contains three windows where are
showing measuring by SMART DEW values
(non-relative and relative humidity and ambient
temperature) and two steering
buttons: Connect and Load chart.

Making connection with the SMART DEW.

To make connection click "Connect" button.
Application will be looking for available serial ports
and trying to find the SMART DEW hygrometer.
After successful operation "Found device" window
with name of founded device will be appeared.
Windows will be showing actual humidity and
ambient temperature. Data will be saving in file
"jrt.txt" on the hard disc drive.

In other case, when hygrometer is wrong
connected or there is no free serial port on the
computer, or it has com number over 8, "Device is
not responding" will be appeared.

Loading saved data.

By clicking button "Load chart" user may read
data saved before in text file. Data will be
automatically read by the graph. On the graph
generated by reading file, user could make all
functions described in "Sheet Graph"

Additional information.

At this sheet is also presented information about
version, revision and serial number of SMART DEW
device, and version of application. This is important
information when you need to contact with
technical support.

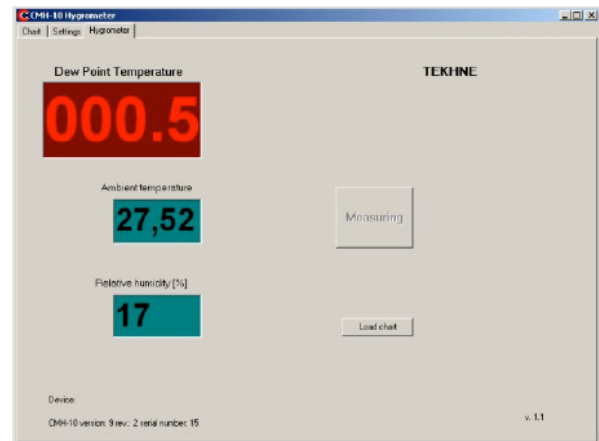

Application window, sheet "Hygrometer"

Sheet "Settings"

This sheet makes possible remote configuration of
the SMART DEW settings. That way is much
easier
and quicker than setting by keys at the front panel
of SMART DEW meter.

Settings are being updated in two cases: after
successful connection operation and after clicking
"Load settings" button. User can edit each setting,
but it will be no consequences, because all changes
in settings are transmitting to the SMART DEW
only
after clicking "Save settings" button.

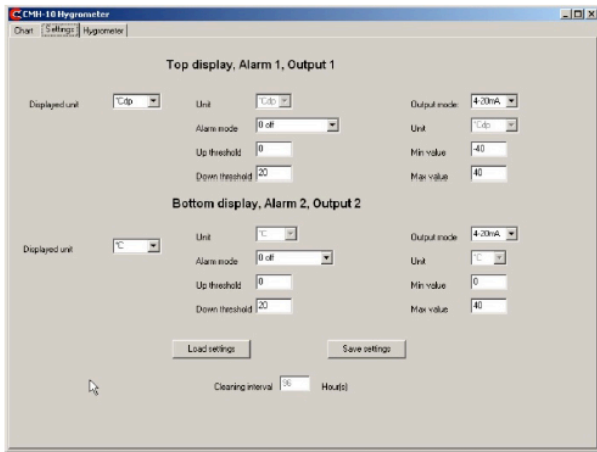

Application window, sheet "Settings"

Sheet "Chart"

This sheet presents graphically measuring (or measured before) non-relative humidity (red line) and ambient temperature (blue line). The graph is autoscaling.

Graph could be magnifying, but it strongly recommended to do it only if there is no connection with SMART DEW. For example when SMART DEW is turned off, or disconnected or (this is right way) when graph is read from saved file. In other case graph will be automatically scaled.

To magnify part of the graph, mouse's cursor should be in the left-up corner of interesting area, then press left mouse's button and move it right-down, selecting interesting part of the graph.

Pressure
Cable length
Weight

Ambient temperature sensor

Unit Electronics

Resolution

Outputs Analogue
Alarm
Digital

Operating temperature

Dimensions

Mounting type

Connectors

Enclosure

Weight

To back to the full scale view, execute similar movement, but left-up with pressing left button. Magnifying area could be moved. By pressing right mouse's button and next moving mouse, graph will be moving too.

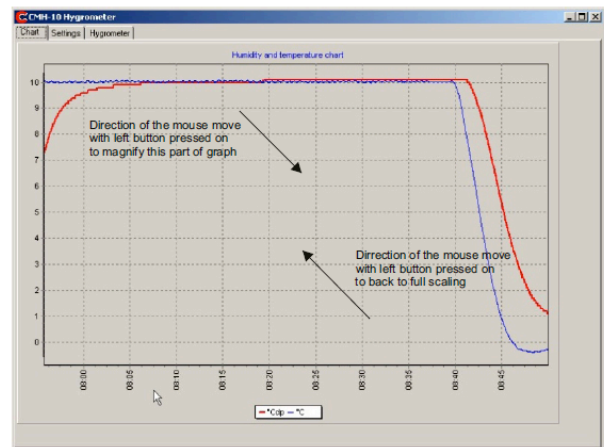

Application window, sheet "Hygrometer"

Technical specifications

General

Measurement range

Measurement accuracy

Measurement units

Power supply

Power consumption

Dew-Point Sensor

Filter

Mirror

Mirror temperature

Sample flow rate

Max velocity

-20 to 60 °C under gas temperature

+/-0.3°C for dew point

+/-0.1°C for ambient temperature

°Cdp, °Fdp, %rh, gm⁻³, a_w, °C, °F, T-Tdp

85-264VAC/ 47- 440Hz

max 15 VA

sintered guard

gold plated cooper

PT100, 1/3 DIN, 4-wire

30m/sec

0.1MPa
3 meters
0.52 kg

PT100, 1/3 DIN, 4-wire

0.1°Cdp, °Fdp, %rh, °C, °F, T-Tdp
0.001 for a_w
automatic for gm^{-3}
two channels 4-20mA or 0-20mA

volt free contact 5A, 250V
RS-232 (RS-485) (Modbus RTU soon)
-10 to 40 ambient
96 x 96 x 120mm
in panel, hole size 91 x 91mm
six screw terminals block
aluminium
0.77kg

TEKHNE

Drawings

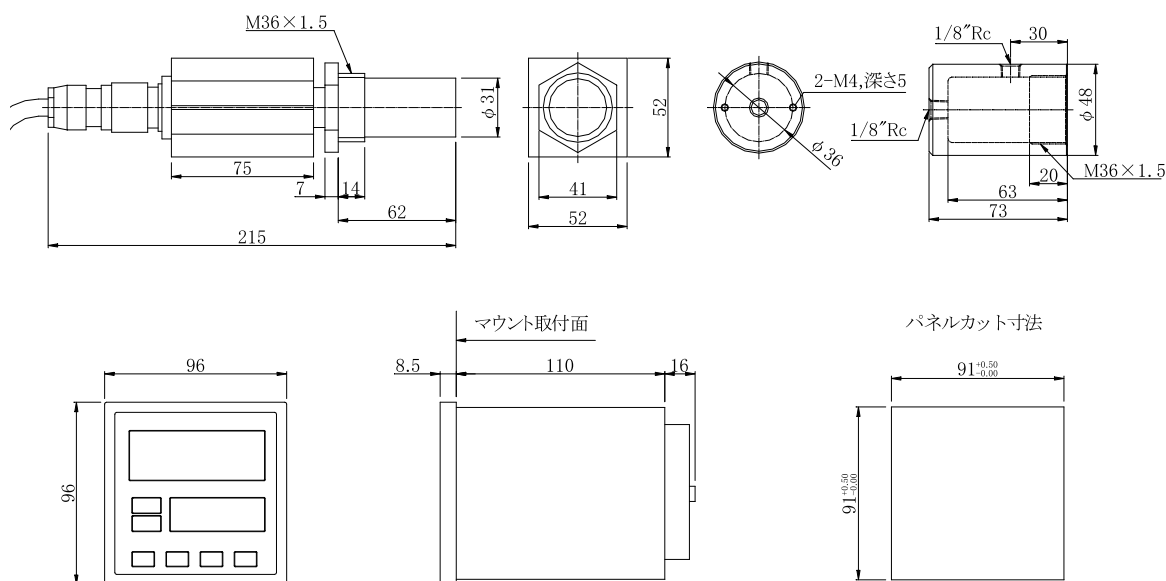

TEKHNE

Tekhne

6-14-10, Futago, Takatsu-ku, Kawasaki-city
Kanagawa 213-0002 Japan
TEL : +81(44)-379-3697 FAX : +81(44)-379-4105
URL : <http://www.tekhne.co.jp>